

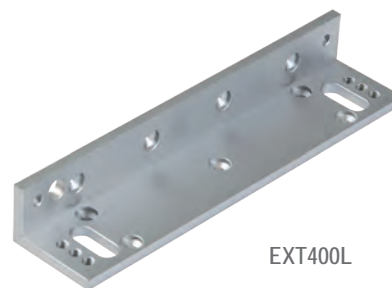

MOUNTING ACCESSORIES

for VELMAG™ EM locks with stainless steel body 370 DaN

- Satin aluminium finishing



EXT400L



EXT400Z

CHARACTERISTICS

Dimensions	EXT400L	33,5 x 220 x 50,5 mm
H x W x D	EXT400Z	101 x 182 x 50,50 mm



Caution:
Fitting recommended inside locked areas

EXT400L

Adjustable L bracket for EXT400CTC

0,3 kg

EXT400Z

Adjustable Z bracket for EXT400CTC

0,5 kg

Customs code
83014019

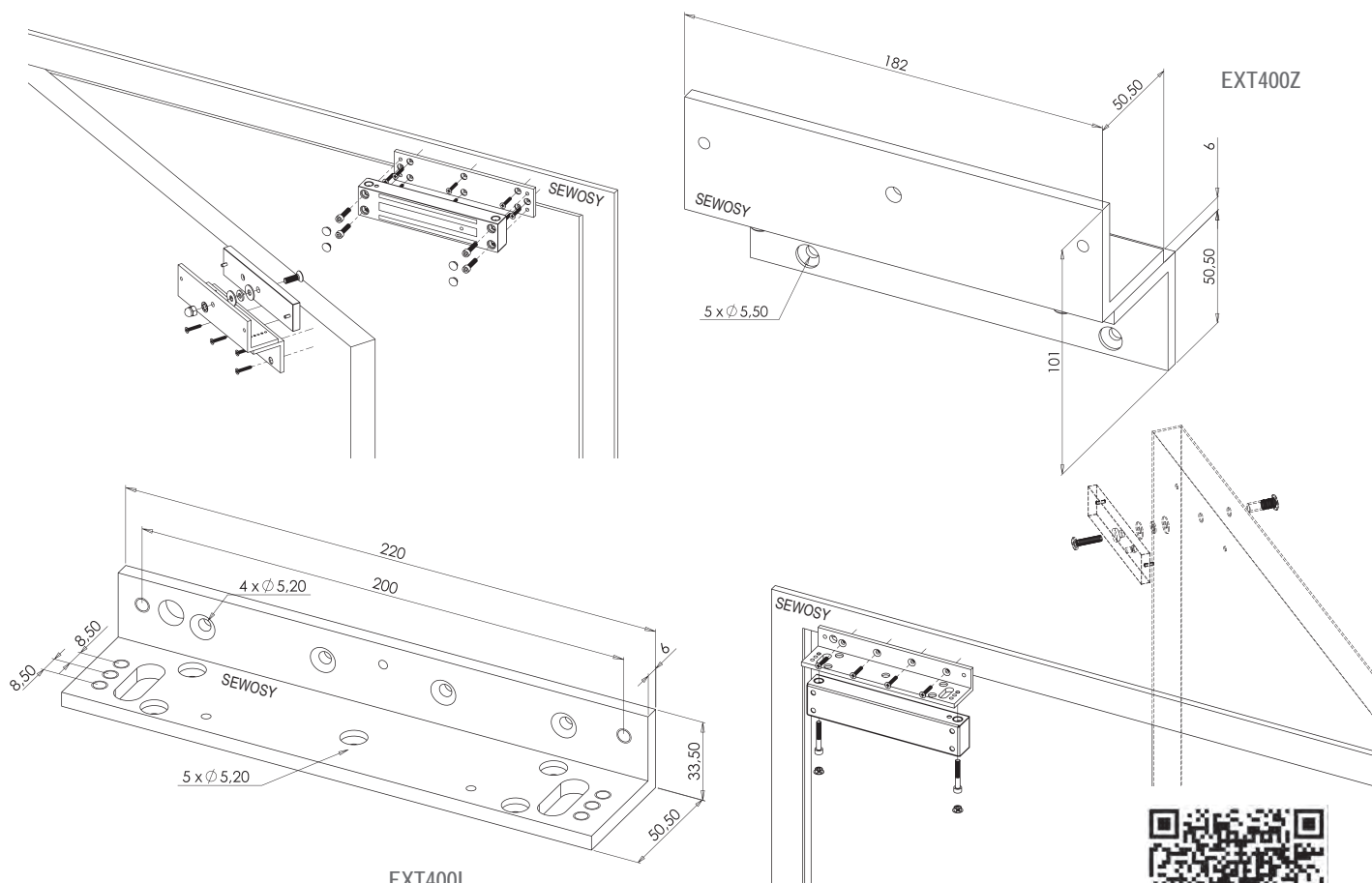

VELMAG™ SURFACE EM LOCKS stainless steel body 370 SERIES